

### 2003- CHEVY SILVERADO SS DUALS 6.0L

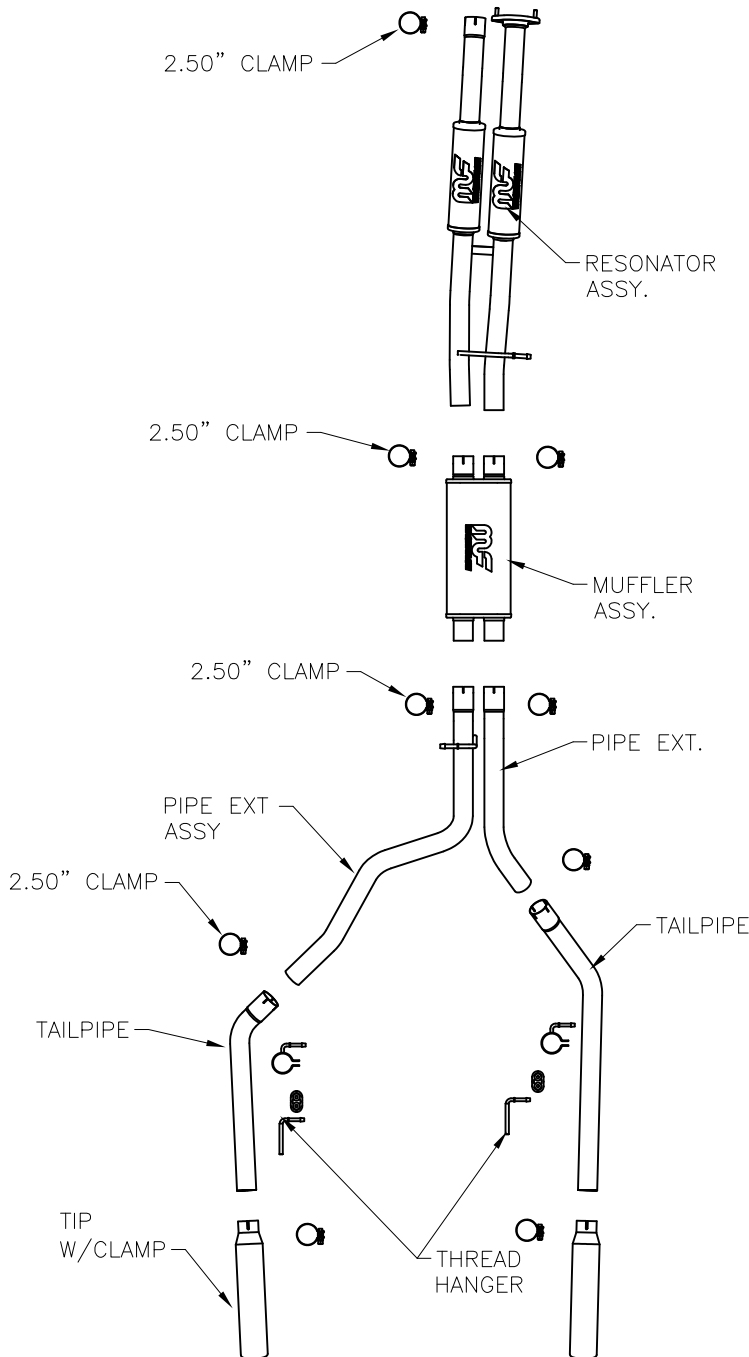

**Warning:** When working on under or around any vehicle exercise caution. Please allow the vehicle's exhaust system to cool before removal, as exhaust system temperatures may cause severe burns. If working without a lift, always consult vehicle manual for correct lifting specifications. Always wear safety glasses and ensure safe work area. Serious injury or death could occur if safety measures are not followed.

**Note:** MAGNAFLOW Performance dual exit truck systems are designed to fit stock-height vehicles with OEM hitches and spare wheel and tire combos. Vehicles with aftermarket components such as trailer hitches, larger spare wheel and tire, or ride height changes may require modification of the exhaust system for a proper fit and finish.

**Step 1:** (Carefully read all instructions before installation) Disconnect the vehicle's battery before removal of the OEM exhaust. This will allow the computer to reset itself with the new system, and prevent electrical accidents. To remove the OEM system, unbolt the tailpipe and muffler at the mating connections, disengage the welded hangers from the OEM rubber insulators and remove the assemblies. Do not damage the rubber insulators, or discard the OEM fasteners, as they will be reused to mount the new system.

**Step 2:** Install the new resonator assembly by fastening it to the catalytic converter extension, using the OEM fasteners and a supplied 2.50" clamp. Leave all clamps and fasteners loose for final adjustments of the complete system. Install the new muffler by fastening it to the resonator assembly using the supplied clamps. Install the pipe extensions and tailpipes in a similar fashion. The threaded hangers are to be fitted to holes in the frame and connected to the tailpipes with the supplied rubber insulators as shown in Diagram 2. The polished tips are supplied with welded clamps for installation, it is recommended to have the tips welded to the tailpipes once a final position has been chosen.

\*MAGNAFLOW Performance Exhaust recommends professional installation on all their products

Technical support: 1-800-959-9226 ext. 4500

2003- CHEVY SILVERADO SS DUALS 6.0L

DIAGRAM 2



**Warning:** When working on under or around any vehicle exercise caution. Please allow the vehicle's exhaust system to cool before removal, as exhaust system temperatures may cause severe burns. If working without a lift, always consult vehicle manual for correct lifting specifications. Always wear safety glasses and ensure safe work area. Serious injury or death could occur if safety measures are not followed.

**Note:** MAGNAFLOW Performance dual exit truck systems are designed to fit stock-height vehicles with OEM hitches and spare wheel and tire combos. Vehicles with aftermarket components such as trailer hitches, larger spare wheel and tire, or ride height changes may require modification of the exhaust system for a proper fit and finish.

**Step 3:** With all components mounted loosely, adjust the system for overall aesthetics and clearance of frame & bodywork. (MAGNAFLOW recommends at least 1/2" of clearance between the exhaust system and any body panels to prevent heat-related body damage or fire.)

**Step 4:** Once a final position has been chosen for the new system, evenly tighten all fasteners from front to rear. The supplied band clamps must be VERY tight to properly align the pipes and prevent leaks (Approximately 40ft-lbs) Inspect all fasteners after 25-50 miles of operation and retighten if necessary.