

2000-2002 Audi A4/S4 2.7L

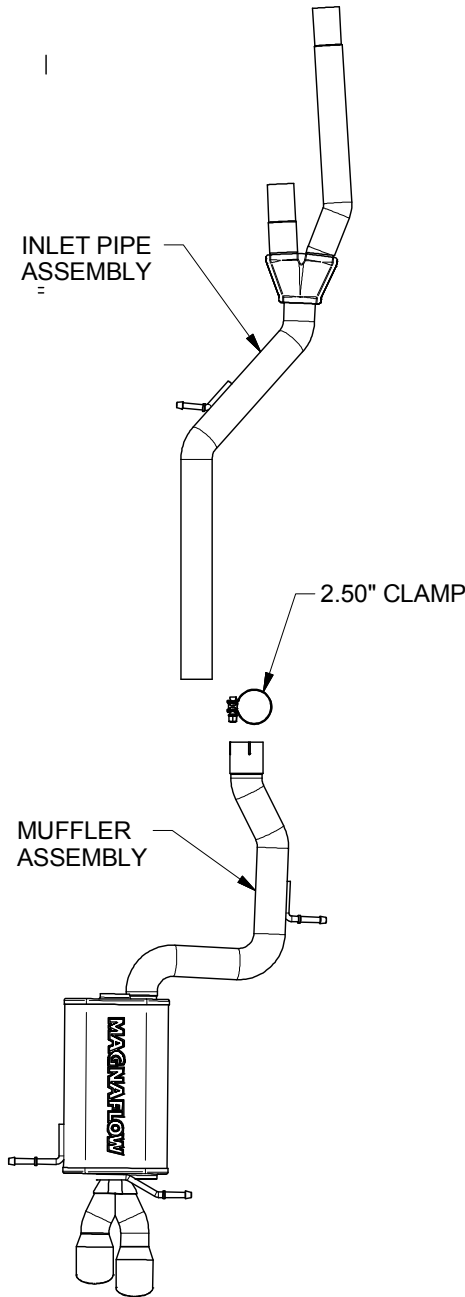

Warning: When working on, under, or around any vehicle exercise caution. Please allow the vehicle's exhaust system to cool before removal, as exhaust system temperatures may cause severe burns. If working without a lift, always consult vehicle manual for correct lifting specifications. Always wear safety glasses and ensure a safe work area. Serious injury or death could occur if safety measures are not followed.

Step 1: Begin removing your OEM exhaust system by first loosening the clamps at the outlet of the catalytic converters. Working front to rear detach all hangers from the rubber isolators. Remove the system from the vehicle.

Step 2: Install your new MAGNAFLOW system by first attaching the inlet pipes of the Inlet Pipe Assembly to the catalytic converter outlets. Locate the hanger to the rubber isolator. Next, slip the inlet of the Muffler Assembly over the Inlet Pipe Assembly and secure with the supplied clamp. Locate the remaining hangers into the rubber isolators.

Step 3: With all components mounted loosely, adjust the system for overall aesthetics and clearance of frame & bodywork. (MAGNAFLOW recommends at least 1/2" of clearance between the exhaust system and any body panels to prevent heat-related body damage or fire.)

Step 4: Once a final position has been chosen for the new system, evenly tighten all fasteners from front to rear. The supplied band clamps must be VERY tight to properly align the pipes and prevent leaks (Approximately 40ft-lbs). U-bolt clamps should be tightened to approximately 30-35ft-lbs. inspect all fasteners after 25-50 miles of operation and retighten if necessary.

**** Magnaflow Performance Exhaust recommends professional installation on all their products**