

1992-1996-Corvette 5.7L V8

Warning: When working on under or around any vehicle exercise caution. Please allow the vehicle's exhaust system to cool before removal, as exhaust system temperatures may cause severe burns. If working without a lift, always consult vehicle manual for correct lifting specifications. Always wear safety glasses and ensure safe work area. Serious injury or death could occur if safety measures are not followed.

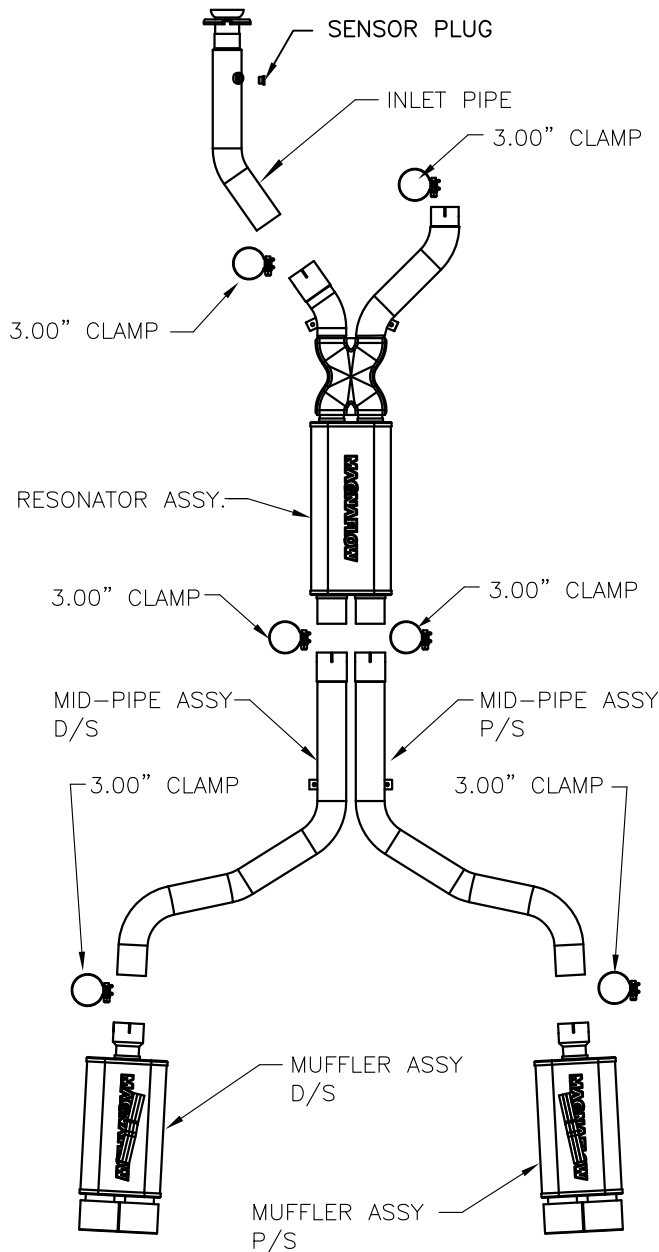

Step 1: (Carefully read all instructions before installation) Disconnect the vehicle's battery before removal of the OEM exhaust system. This will allow the computer to reset itself with the new exhaust system and prevent electrical accident. To begin removal of the OEM system first remove the X shaped cross member for easier access to the exhaust and un-bolt the O2 sensor. Next, unbolt the rear muffler insulators at the back of the vehicle, you can leave them attached to the muffler hangers but this will facilitate easier removal of the exhaust later. Unbolt the front flange where it connects with the driver's side catalytic converter and loosen the band clamp from tube exiting the passenger side catalytic converter. Finally unbolt the spring loaded hangers. The complete exhaust assembly can now be removed. RETAIN all mounting hardware as it will be needed to mount your new system.

Step 2: Begin installation of the new system by re-attaching the rear OEM muffler hangers. Fasten the Inlet Pipe to the driver side catalytic converter extension using the OEM hardware. Leave all clamps and fasteners loose for final adjustment of the complete system. Install the Resonator Assembly using the supplied 3.00" clamps and by fitting the OEM hanger hardware. Install the driver and passenger side mid-pipe assemblies in a similar fashion. Finally install the muffler assemblies

Step 3: With all components mounted loosely, adjust the system for overall aesthetics and clearance of frame & bodywork. (MAGNAFLOW recommends at least 1/2" of clearance between the exhaust system and any body panels to prevent heat-related body damage or fire.)

Step 4: Once a final position has been chosen for the new system, evenly tighten all fasteners from front to rear install O2 sensor. Some vehicles will not have this O2 sensor, use the supplied plug for the sensor bushing. The supplied band clamps must be VERY tight to properly align the pipes and prevent leaks (approximately 40ft-lbs). inspect all fasteners after 25-50 miles of operation and retighten if necessary.

Technical support: 1-800-959-9226 ext. 4500

*MAGNAFLOW Performance Exhaust recommends professional installation on all their products