

2011 - CHRYSLER 300 V6 3.6L

Warning: When working on, under, or around any vehicle exercise caution. Please allow the vehicle's exhaust system to cool before removal, as exhaust system temperatures may cause severe burns. If working without a lift, always consult vehicle manual for correct lifting specifications. Always wear safety glasses and ensure a safe work area. Serious injury or death could occur if safety measures are not followed.

Step 1: (Carefully read all instructions before installation) Begin loosening the existing OEM exhaust system by loosening the OEM clamps located behind the catalyst converters. Remove the welded hangers from the OEM rubber insulators. Do not damage the OEM rubber insulators, as they will be reused to install the new exhaust system. The OEM exhaust system can be cut behind the mid muffler to aid in the removal of the OEM exhaust system.

Step 2: Install the new exhaust system using a front to rear method. Using two supplied 2.25" clamps, install the Front Y-pipe Assembly. Leave all fasteners loose for final adjustment of the complete system. Using a supplied 2.50" clamp, install the Mid Muffler Assembly. Complete the installation of the Mid Muffler Assembly by fitting the welded hanger into the OEM Rubber Insulator. Using a supplied 2.50" clamp, install the Rear Y-pipe Assembly. Using a supplied 2.25" clamp, install the Passenger's Side Muffler Assembly. Complete the installation by fitting the welded hangers into the OEM insulators. Fit the Driver's Side Muffler Assembly in place installing the front and rear welded hangers and the supplied 2.25" clamp.

Step 3: With all components mounted loosely, adjust the system for overall aesthetics and clearance of frame & bodywork. (MAGNAFLOW recommends at least 1/2" of clearance between the exhaust system and any body panels to prevent heat-related body damage or fire.)

Step 4: Once a final position has been chosen for the new system, evenly tighten all fasteners from front to rear. The supplied band clamps must be VERY tight to properly align the pipes and prevent leaks (approximately 40ft. lbs.) Inspect all fasteners after 25-50 miles of operation and retighten if necessary

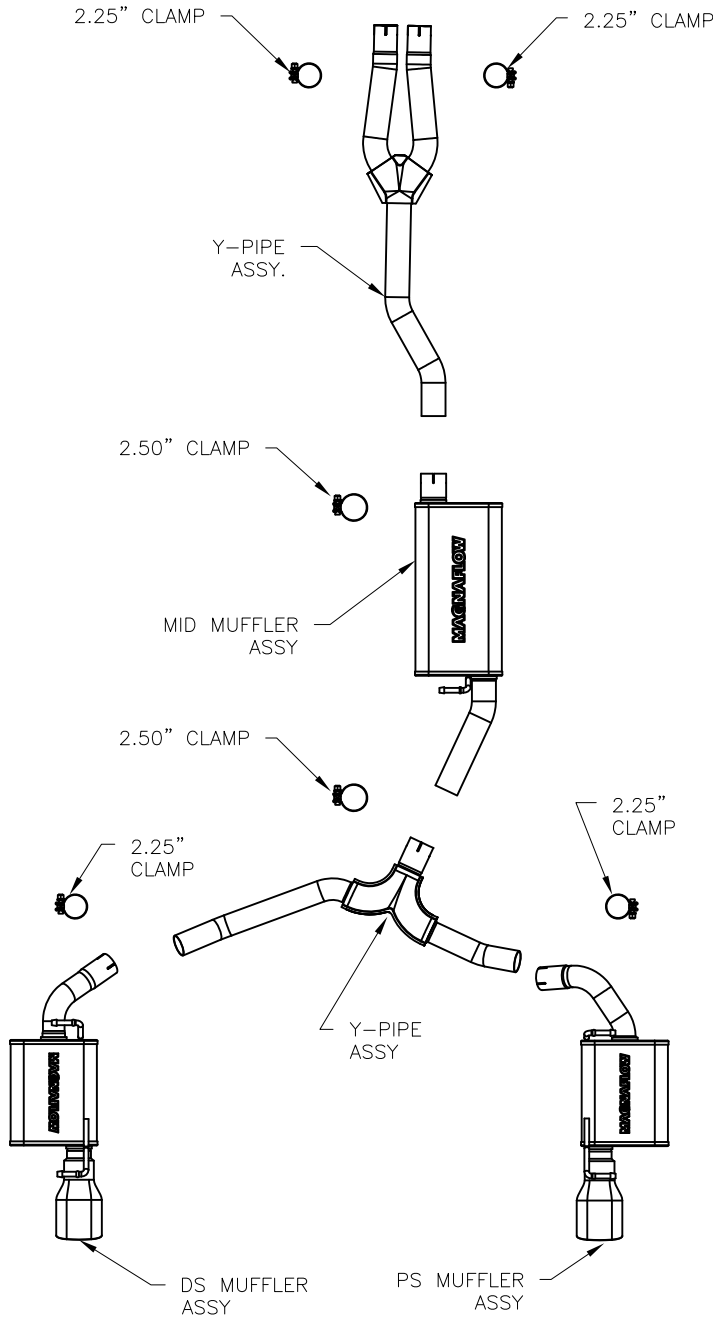

*MAGNAFLOW Performance Exhaust recommends professional installation on all their products

Technical support: 1-800-959-9226 ext. 4500