

2012 Hyundai Sonata 2.0L Turbo

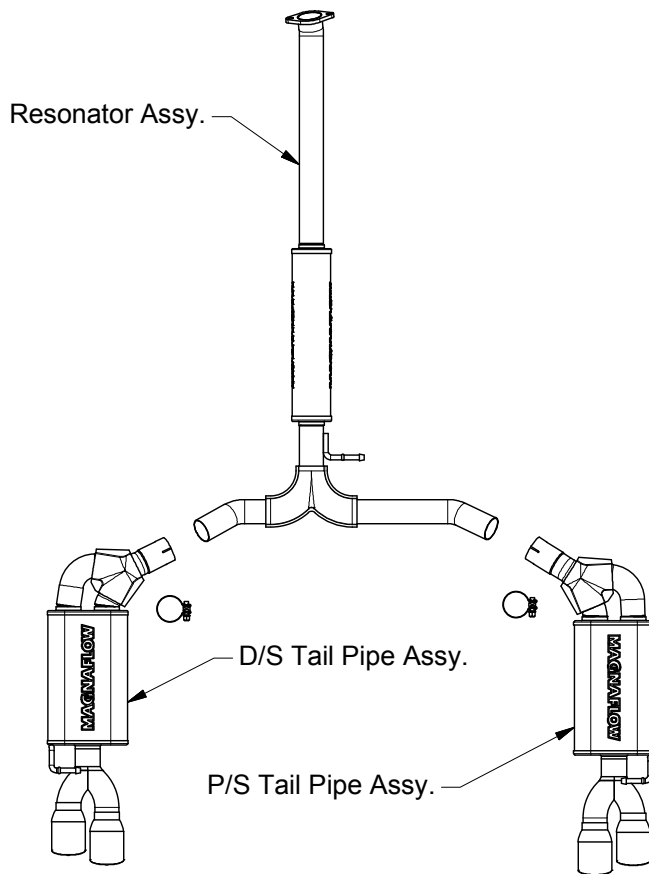

Warning: When working on, under, or around any vehicle exercise caution. Please allow the vehicle's exhaust system to cool before removal, as exhaust system temperatures may cause severe burns. If working without a lift, always consult vehicle manual for correct lifting specifications. Always wear safety glasses and ensure a safe work area. Serious injury or death could occur if safety measures are not followed.

Step 1: (Carefully read all instructions before installation) To remove the OEM system, first unbolt the inlet flange behind the catalytic converters. Disengage the welded hangers from the rubber insulators, and remove the OEM system from the vehicle. Be sure to retain all mounting hardware as it will be needed to install your new MAGNAFLOW performance system.

Step 2: Begin installing the resonator assembly to the catalytic converter outlet using the OEM fasteners. Install both new tail pipe assemblies using the supplied 2.50" band clamps. Working front to rear locate all welded hangers to the rubber insulators. Leaving all clamps and fasteners loose for final adjustment of the complete system.

Step 3: With all components mounted loosely, adjust the system for overall aesthetics and clearance of frame & bodywork. (MAGNAFLOW recommends at least 1/2" of clearance between the exhaust system and any body panels to prevent heat-related body damage or fire.)

Step 4: Once a final position has been chosen for the new system, evenly tighten all fasteners from front to rear. The supplied band clamps must be VERY tight to properly align the pipes and prevent leaks (Approximately 40ft-lbs). Inspect all fasteners after 25-50 miles of operation and retighten if necessary.

□

**** Magnaflow Performance Exhaust recommends professional installation on all their products**