



INSTALLATION INSTRUCTIONS



2014-2017 CHEVROLET SILVERADO 5.3L | PART NO. 15267

BILL OF MATERIALS:

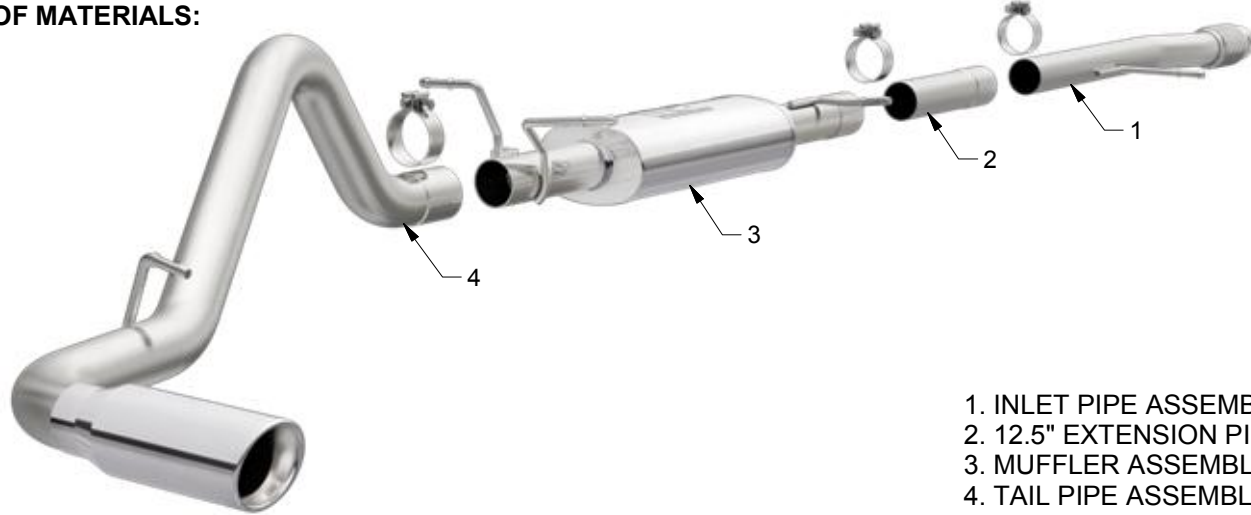

- 1. INLET PIPE ASSEMBLY
- 2. 12.5" EXTENSION PIPE
- 3. MUFFLER ASSEMBLY
- 4. TAIL PIPE ASSEMBLY



WEAR SAFETY GLASSES



READ INSTRUCTIONS THOROUGHLY BEFORE INSTALLING PRODUCT

SHOP SUPPLIES:



SPRAY LUBRICANT

To ease removal of existing exhaust components (especially on older vehicles) spray penetrating lubricant on all fasteners and hangers/insulators that will be loosened or removed and let soak before disassembly.

HARDWARE KIT:

- 1. [3] 3.00" Clamp

MINIMUM REQUIRED TOOLS:



15mm



Hanger Tool (Or Pry Bar)

MAGNAFLOW RECOMMENDS PROFESSIONAL INSTALLATION ON ALL THEIR PRODUCTS



WARNING: When working on, under, or around any vehicle exercise caution. Please allow the vehicle's exhaust system to cool before removal, as exhaust system temperatures may cause severe burns. If working without a lift always consult vehicle manual for correct lifting specifications. Always wear safety glasses and ensure a safe work area. Serious injury or death could occur if safety measures are not followed.

ATTENTION: Always install any supplied band or U-bolt clamps to the proper torque specifications of 40-45 ft-lbs for band clamps and 30-35 ft-lbs for U-bolt clamps. Over tightening will result in the clamp breaking and will NOT be warranted by MagnaFlow.

INSTALLATION INSTRUCTIONS



Step 1. To remove the OEM exhaust loosen the clamp at the ball flare junction attaching the inlet pipe to the catalytic converter outlet. Working front to rear disengage all welded hangers from the rubber insulators. Be sure to retain all mounting hardware as it will be needed to install your new MAGNAFLOW system.

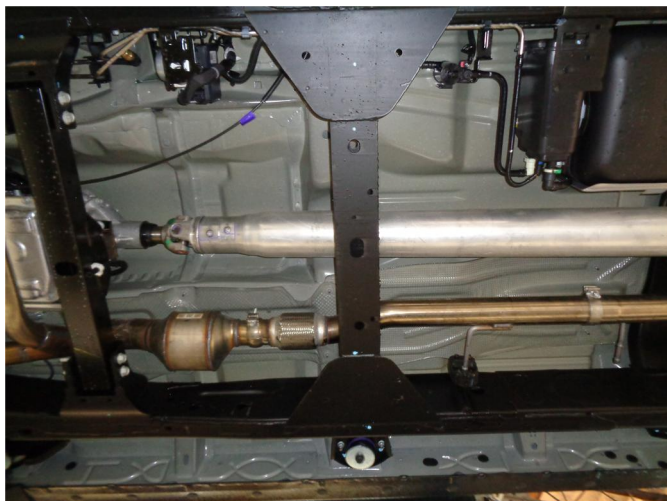

Step 2. Begin installation by loosely attaching the Inlet Pipe Assembly to the catalytic converter ball flare using the OEM hardware. Engage the welded hanger to the rubber insulator.

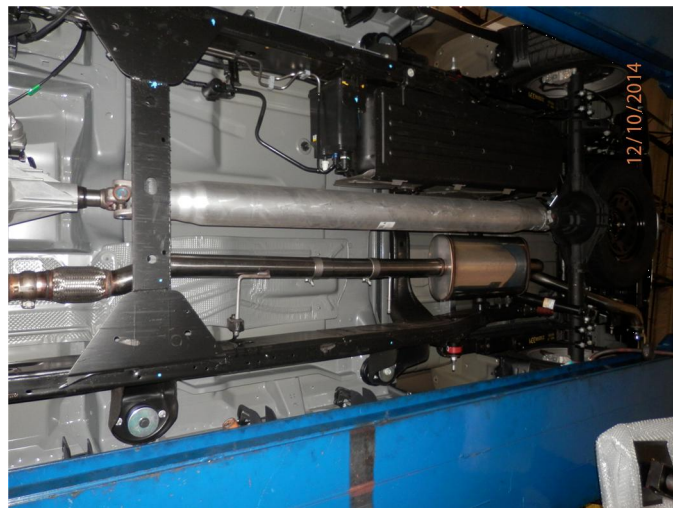

Step 3. Crew Cab Short Bed vehicles only will require the 12.5" Extension Pipe to be fitted between the Inlet Pipe Assembly and the Muffler Assembly. Loosely attach the Muffler Assembly using the supplied clamps. Engage all welded hangers to the rubber insulators.



Step 4. Next loosely attach the Tail Pipe Assembly to the valve outlet on the Muffler Assembly using the supplied clamp. Engage the welded hanger to the rubber insulator.



Step 5. Once a final position has been chosen for the new exhaust system, evenly tighten all clamps from front to rear using the torque specifications on page one of the instructions. Inspect all fasteners after 25-50 miles of operation and re-tighten if necessary.