



# INSTALLATION INSTRUCTIONS



2013-2014 FORD F-150 3.7L | PART NO. 15324

## BILL OF MATERIALS:

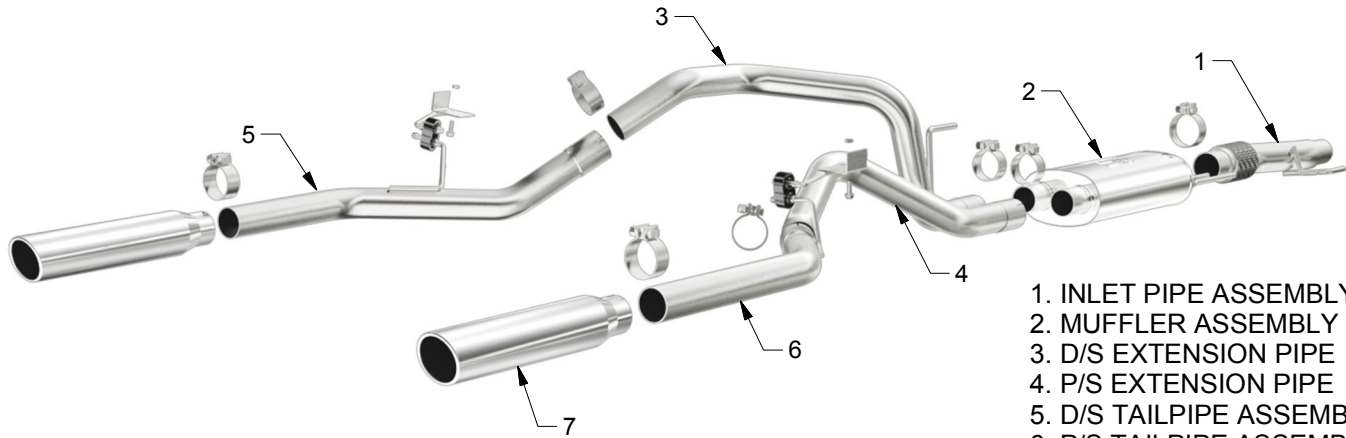

- 1. INLET PIPE ASSEMBLY
- 2. MUFFLER ASSEMBLY
- 3. D/S EXTENSION PIPE
- 4. P/S EXTENSION PIPE
- 5. D/S TAILPIPE ASSEMBLY
- 6. P/S TAILPIPE ASSEMBLY
- 7. TIPS



WEAR SAFETY GLASSES



READ INSTRUCTIONS THOROUGHLY BEFORE INSTALLING PRODUCT

## SHOP SUPPLIES:



SPRAY LUBRICANT

To ease removal of existing exhaust components (especially on older vehicles) spray penetrating lubricant on all fasteners and hangers/insulators that will be loosened or removed and let soak before disassembly.

## HARDWARE KIT:

- 1.[6] 2.50" Clamp
- 2.[1] 3.00" Clamp
- 3.[2] Rubber Insulator
- 4.[1] Hanger Assy D/S
- 5.[1] Hanger Assy P/S
- 5.[2] Nut U-Type 8mm-1.25
- 6.[2] Bolt 8mm-1.25

## MINIMUM REQUIRED TOOLS:



13mm  
15mm



Hanger Tool  
(Or Pry Bar)



7/8"



Sawzall or other cutting device.

## MAGNAFLOW RECOMMENDS PROFESSIONAL INSTALLATION ON ALL THEIR PRODUCTS



**WARNING:** When working on, under, or around any vehicle exercise caution. Please allow the vehicle's exhaust system to cool before removal, as exhaust system temperatures may cause severe burns. If working without a lift always consult vehicle manual for correct lifting specifications. Always wear safety glasses and ensure a safe work area. Serious injury or death could occur if safety measures are not followed.

**ATTENTION:** Always install any supplied band or U-bolt clamps to the proper torque specifications of 40-45 ft-lbs for band clamps and 30-35 ft-lbs for U-bolt clamps. Over tightening will result in the clamp breaking and will NOT be warranted by MagnaFlow.

MAGNAFLOW: 22961 Arroyo Vista - Rancho Santa Margarita, CA 92688 | 1(800) 990-0905  
Technical Support: 1(800) 959-9226 | Email: [moreinfo@magnaflow.com](mailto:moreinfo@magnaflow.com)

## INSTALLATION INSTRUCTIONS



**Step 1.** The new exhaust system requires that you permanently remove the spare tire from the vehicle. To remove the OEM exhaust system, you will need to cut the pipe behind the muffler before it goes over the axle. You can then disengage the welded hangers from the OEM rubber insulators and remove the tailpipe.

Unfasten the clamp attaching the OEM muffler inlet to the OEM catalytic converter. Do not damage or discard the OEM fasteners or rubber insulators, as they will be reused to mount the new system. Disengage the muffler hangers and remove the OEM exhaust from the vehicle.



**Step 2.** To begin, fasten the Inlet Pipe Assembly to the catalytic converter using the OEM clamp assembly and by fitting the welded hanger into the OEM rubber insulator (Leave all clamps and fasteners loose for final adjustment of the complete system.) Install the Muffler to the Inlet Pipe Assembly using the supplied 3.00" clamp. Next install the Tailpipe Extensions to the Muffler in the similar fashion using the supplied 2.50" clamps.

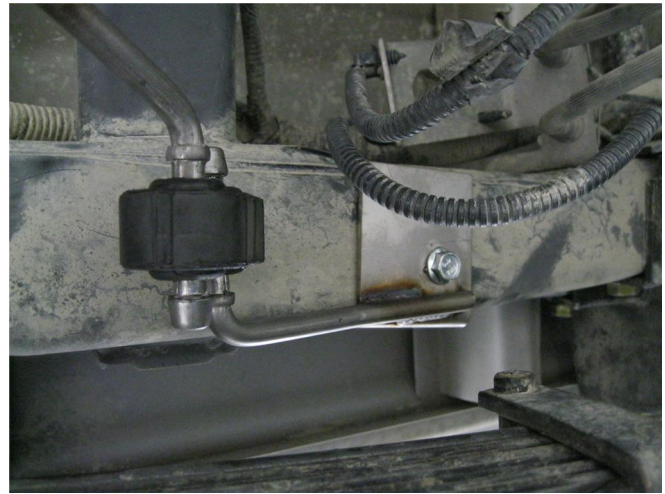

**Step 3.** Next you will need to use the supplied U-Nuts and attach them to the receiving cut outs in the bottom of the frame rail. Fasten the supplied hanger assemblies to the frame members using the supplied bolts on both the Driver and Passenger side. Install the Tail Pipe Assemblies to the Tail Pipe Extensions using the supplied 2.50" clamp, fitting the welded hangers into rubber insulators.



**Step 4.** Lastly, install the tips to the Tail pipe Assemblies using the supplied 2.50" clamps. The supplied adjustable tips are design to fit a variety of aftermarket bumpers and rollpans, once a position is decided for the tips it is recommended to have them welded into place.



**Step 5.** Once a final position has been chosen for the new exhaust system, evenly tighten all clamps from front to rear using the torque specifications on page one of the instructions. Inspect all fasteners after 25-50 miles of operation and re-tighten if necessary.