

2011 Mazda 2 1.5L

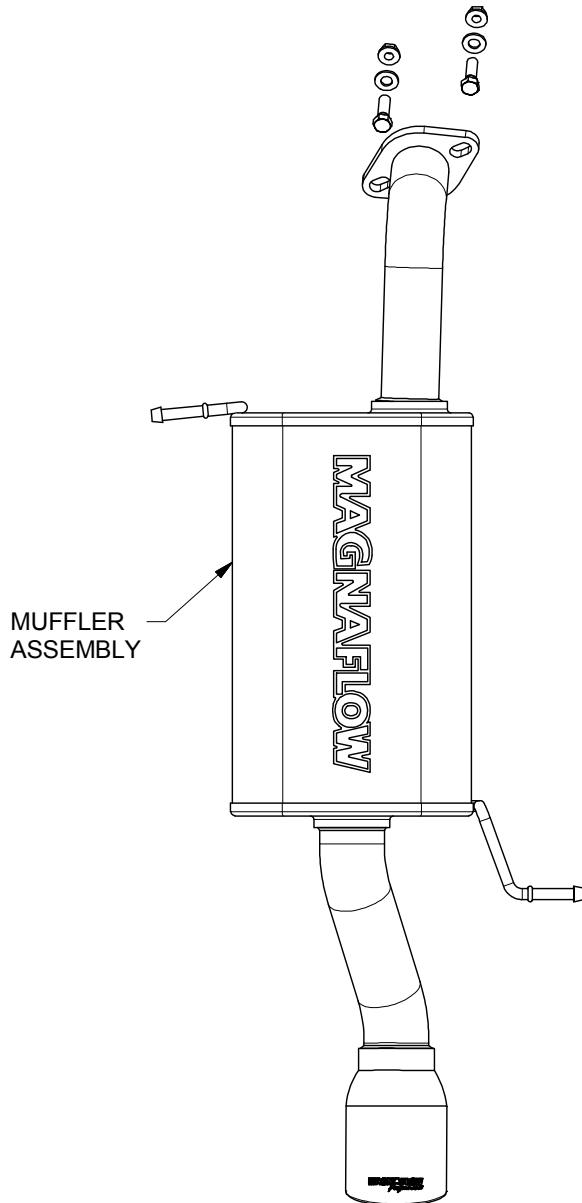

Warning: When working on, under, or around any vehicle exercise caution. Please allow the vehicle's exhaust system to cool before removal, as exhaust system temperatures may cause severe burns. If working without a lift, always consult vehicle manual for correct lifting specifications. Always wear safety glasses and ensure a safe work area. Serious injury or death could occur if safety measures are not followed.

Step 1: (Carefully read all instructions before installation) Begin removal of the OEM exhaust system by unfastening the OEM nuts and bolts located behind the catalytic converter. Do not damage or discard the rubber insulators, as they will be reused to mount the new system. Disengage the welded hangers from the OEM rubber insulators and remove the rear OEM exhaust system.

Step 2: To install the muffler assembly bolt the inlet flange to the outlet end of the catalytic converter using the provided fasteners. Then Insert the welded hangers into the OEM rubber insulator.

Step 3: With all components mounted loosely, adjust the system for overall aesthetics and clearance of frame & bodywork. (MAGNAFLOW recommends at least 1/2" of clearance between the exhaust system and any body panels to prevent heat-related body damage or fire.)

Step 4: Once a final position has been chosen for the new system, evenly tighten all fasteners from front to rear. Inspect all fasteners after 25-50 miles of operation and retighten if necessary.

**** Magnaflow Performance Exhaust recommends professional installation on all their products**