



# INSTALLATION INSTRUCTIONS



'10-'13 INFINITI QX56/NISSAN ARMADA 5.6L | PART NO. 15575

## BILL OF MATERIALS:

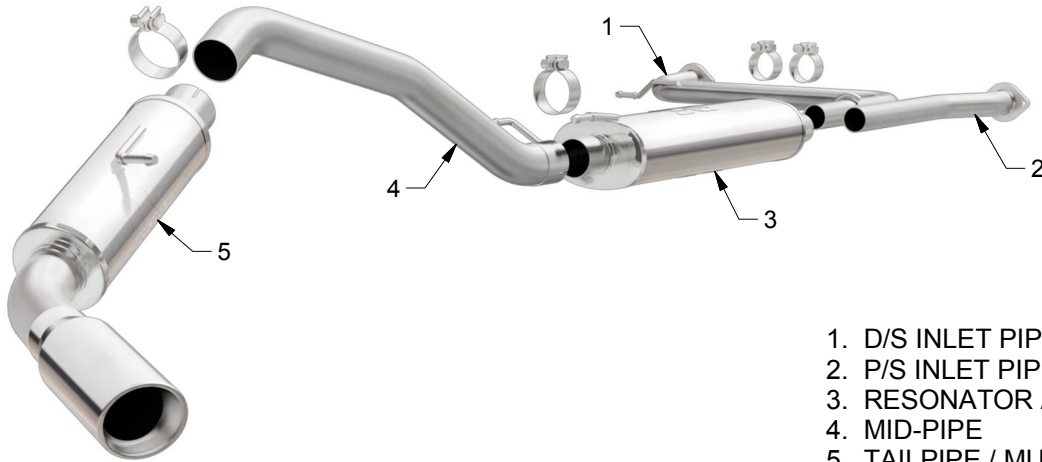

- 1. D/S INLET PIPE.
- 2. P/S INLET PIPE.
- 3. RESONATOR ASSY
- 4. MID-PIPE
- 5. TAILPIPE / MUFFLER ASSY



WEAR SAFETY GLASSES



READ INSTRUCTIONS THOROUGHLY BEFORE INSTALLING PRODUCT



SPRAY LUBRICANT

To ease removal of existing exhaust components (especially on older vehicles) spray penetrating lubricant on all fasteners and hangers/insulators that will be loosened or removed and let soak before disassembly.

## HARDWARE KIT:

- 1. [2] 2.25" Clamp
- 2. [2] 3.00" Clamp

## MINIMUM REQUIRED TOOLS:



15mm  
13mm



Hanger Tool  
(Or Pry Bar)

## MAGNAFLOW RECOMMENDS PROFESSIONAL INSTALLATION ON ALL THEIR PRODUCTS



**WARNING:** When working on, under, or around any vehicle exercise caution. Please allow the vehicle's exhaust system to cool before removal, as exhaust system temperatures may cause severe burns. If working without a lift always consult vehicle manual for correct lifting specifications. Always wear safety glasses and ensure a safe work area. Serious injury or death could occur if safety measures are not followed.

**ATTENTION:** Always install any supplied band or U-bolt clamps to the proper torque specifications of 40-45 ft-lbs for band clamps and 30-35 ft-lbs for U-bolt clamps. Over tightening will result in the clamp breaking and will NOT be warranted by MagnaFlow.

## INSTALLATION INSTRUCTIONS



**Step 1.** To remove the OEM exhaust system begin by un-fastening the 2 bolt flanges at the catalytic converter outlets and behind the muffler. Next, working rearward with the exhaust supported disengage the hangers from the rubber insulators and remove the system. Do not damage or discard the rubber insulators or fasteners as they will be re-used to mount the new system.

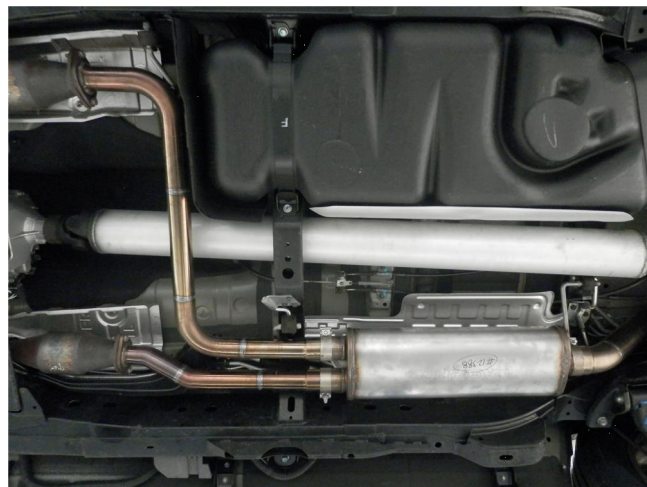

**Step 2.** Begin installation of the new system by attaching the Driver and Passenger side Inlet Assemblies to the catalytic converter outlets using the OEM fasteners and fitting the hangers into the rubber insulators. Next, Install the Resonator Assembly using the supplied 2.25" clamps and fit the welded hangers .

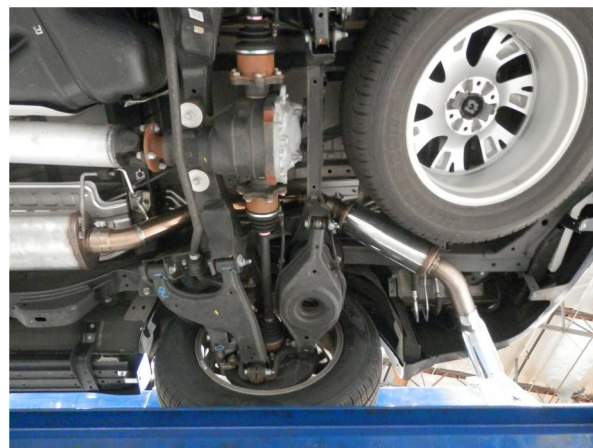

**Step 3.** Next Install the Mid pipe to the Resonator Assembly using a supplied 3.00" clamp. Complete the installation by attaching the Tailpipe / Muffler Assembly using the supplied 3.00" clamp and fit the welded hanger into the rubber insulator.



**Step 4.** Once a final position has been chosen for the new exhaust system, evenly tighten all clamps from front to rear using the torque specifications on page one of the instructions. Inspect all fasteners after 25-50 miles of operation and re-tighten if necessary.