

2004 MAZDA 3 2.0L, 2.3L DOHC I-4

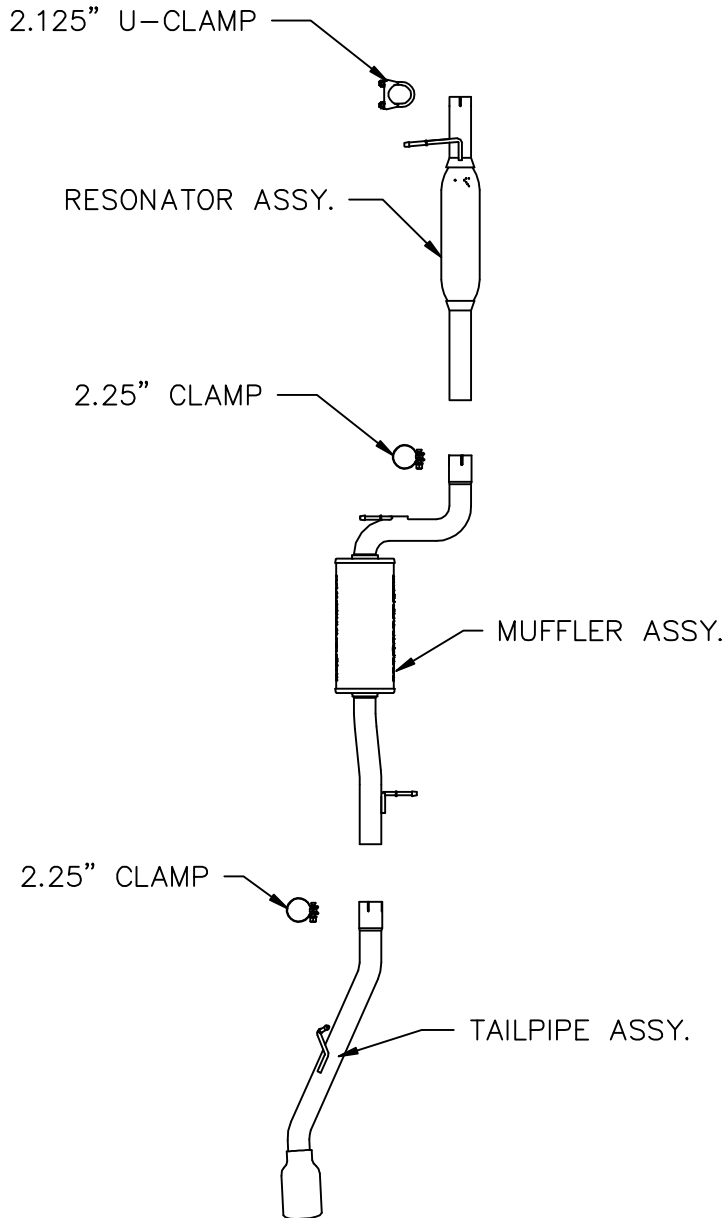

Warning: When working on, under, or around any vehicle exercise caution. Please allow the vehicle's exhaust system to cool before removal, as exhaust system temperatures may cause severe burns. If working without a lift, always consult vehicle manual for correct lifting specifications. Always wear safety glasses and ensure a safe work area. Serious injury or death could occur if safety measures are not followed.

Step 1: (Carefully read all instructions before installation) Disconnect the vehicle's battery before removal of the OEM exhaust. This will allow the computer to reset itself with the new system, and prevent electrical accidents. Removal of the exhaust system on vehicles with a 2.0L engine requires cutting and deburring the pipe 20" behind the flex-pipe flange. Removal of the exhaust system on vehicles with a 2.3L engine requires cutting and deburring the pipe 3.50" behind the secondary catalytic converter. After the pipe has been cut, remove the system by disengaging the welded hangers from the OEM rubber insulators. Do not damage the rubber insulators, as they will be used to mount the new system.

Step 2: Begin installation of the new system by fastening the new resonator assembly to the catalytic converter extension using the supplied 2.125" U-clamp, and by fitting the welded hanger into the OEM rubber insulator. Leave all clamps and fasteners loose for final adjustment of the complete system. Install the muffler and tailpipe assemblies in a similar fashion using the supplied 2.25" band clamps.

Step 3: With all components mounted loosely, adjust the system for overall aesthetics and clearance of frame & bodywork. (MAGNAFLOW recommends at least 1/2" of clearance between the exhaust system and any body panels to prevent heat-related body damage or fire.)

Step 4: Once a final position has been chosen for the new system, evenly tighten all fasteners from front to rear. The supplied band clamps must be VERY tight to properly align the pipes and prevent leaks (Approximately 40ft-lbs.) Inspect all fasteners after 25-50 miles of operation and retighten if necessary.

***MAGNAFLOW Performance Exhaust recommends professional installation on all their products**

Technical support: 1-800-959-9226 ext. 4500

MAGNAFLOW Performance Exhaust — 22961 Arroyo Vista — Rancho Santa Margarita, CA 92688