

'66-'72 GM C-10 / C-20

Warning: When working on, under, or around any vehicle exercise caution. Please allow the vehicle's exhaust system to cool before removal, as exhaust system temperatures may cause severe burns. If working without a lift, always consult vehicle manual for correct lifting specifications. Always wear safety glasses and ensure a safe work area. Serious injury or death could occur if safety measures are not followed.

Step 1: (Carefully read all instructions before installation)

Disconnect the vehicle's battery before removal of the OEM exhaust. This will allow the computer to reset itself with the new system, and prevent electrical accidents. Begin removing the existing exhaust system from the exhaust manifold or header. The existing exhaust system may need to be cut in various locations for complete removal. Take notice of axle position and brake line positions.

Step 2: Begin installing the new exhaust system by fitting the new Inlet pipes, Tru-X connector, Mid pipes, Mufflers and tailpipes into place for a mock-up fitment, as shown on Dia. 1. This will help determine where to locate and install the provided mid bracket hangers and the rear threaded hangers on the frame of the vehicle. Using the provided hanger accessories, the mid hanger bracket will be mounted to the frame of the vehicle, as shown in Dia. 2 & 3. Using the provided hanger accessories, the rear threaded hanger will be mounted to the frame of the vehicle. Then fit the welded hangers to the rubber insulator, as shown on Dia. 4. This will also help to determine where to cut and modify the inlet pipes, as needed to fit existing manifold/header. See Dia. 5.

Step 3: With all components mounted loosely, adjust the system for overall aesthetics and clearance of frame & bodywork. (MAGNAFLOW recommends at least 1/2" of clearance between the exhaust system and any body panels, including areas with moving parts (axles, driveshaft, ect) to prevent heat-related body damage or fire.)

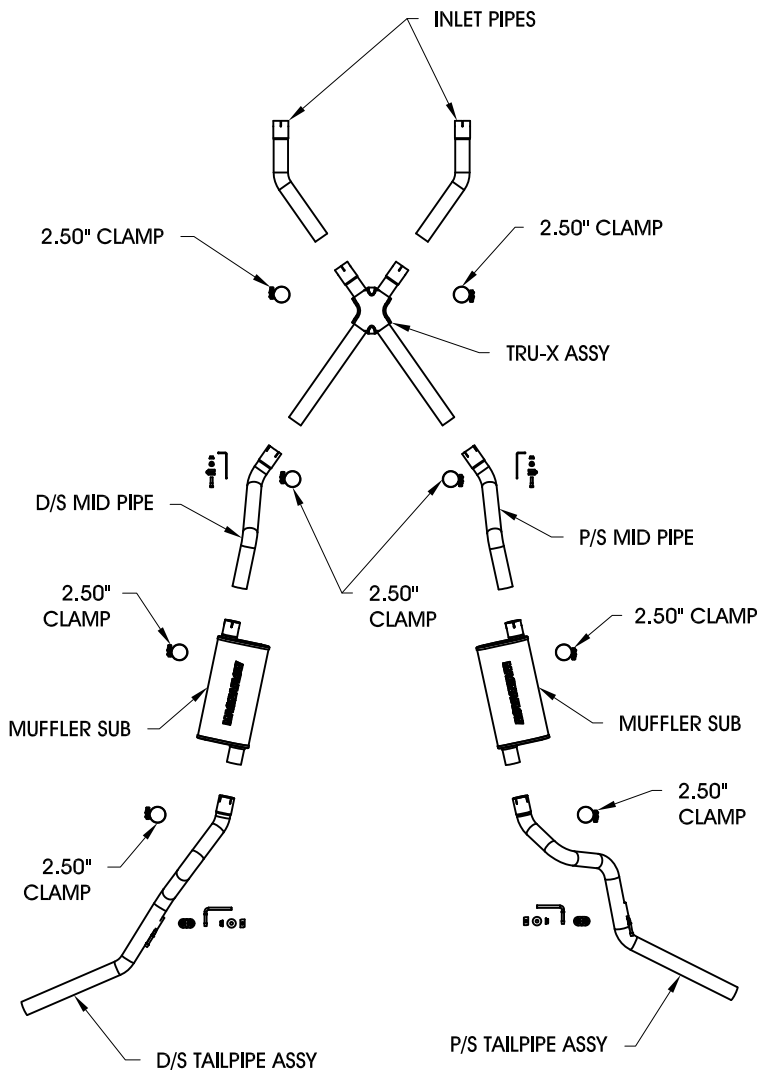

DIAGRAM 1

*MAGNAFLOW Performance Exhaust recommends professional installation on all their products

Technical support: 1-800-959-9226 ext. 4500

'66-'72 GM C-10 / C-20



DIAGRAM "2"

Warning: When working on, under, or around any vehicle exercise caution. Please allow the vehicle's exhaust system to cool before removal, as exhaust system temperatures may cause severe burns. If working without a lift, always consult vehicle manual for correct lifting specifications. Always wear safety glasses and ensure a safe work area. Serious injury or death could occur if safety measures are not followed.

Step 4: Once a final position has been chosen for the new system, evenly tighten all fasteners from front to rear. The supplied band clamps must be VERY tight to properly align the pipes and prevent leaks. Weld the inlet pipes to the manifolds or header. Bend and weld the mid hanger brackets to the mid pipes. Inspect all fasteners after 25-50 miles of operation and retighten if necessary.

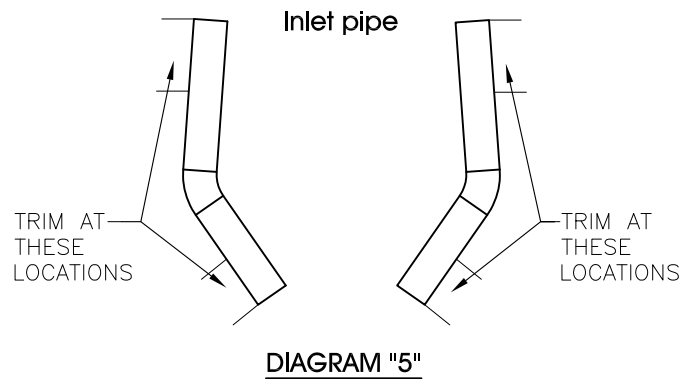
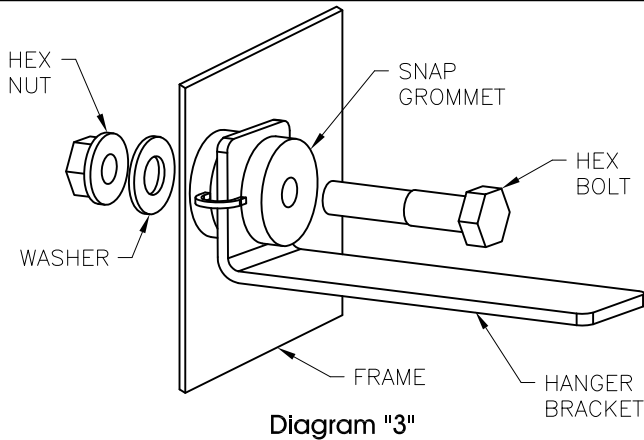

DIAGRAM "4"



DIAGRAM "6"

*MAGNAFLOW Performance Exhaust recommends professional installation on all their products

Technical support: 1-800-959-9226 ext. 4500