

2004- FORD ESCAPE/TRIBUTE 2.0L I-4 / 3.0L V6

Warning: When working on, under, or around any vehicle exercise caution. Please allow the vehicle's exhaust system to cool before removal, as exhaust system temperatures may cause severe burns. If working without a lift, always consult vehicle manual for correct lifting specifications. Always wear safety glasses and ensure a safe work area. Serious injury or death could occur if safety measures are not followed.

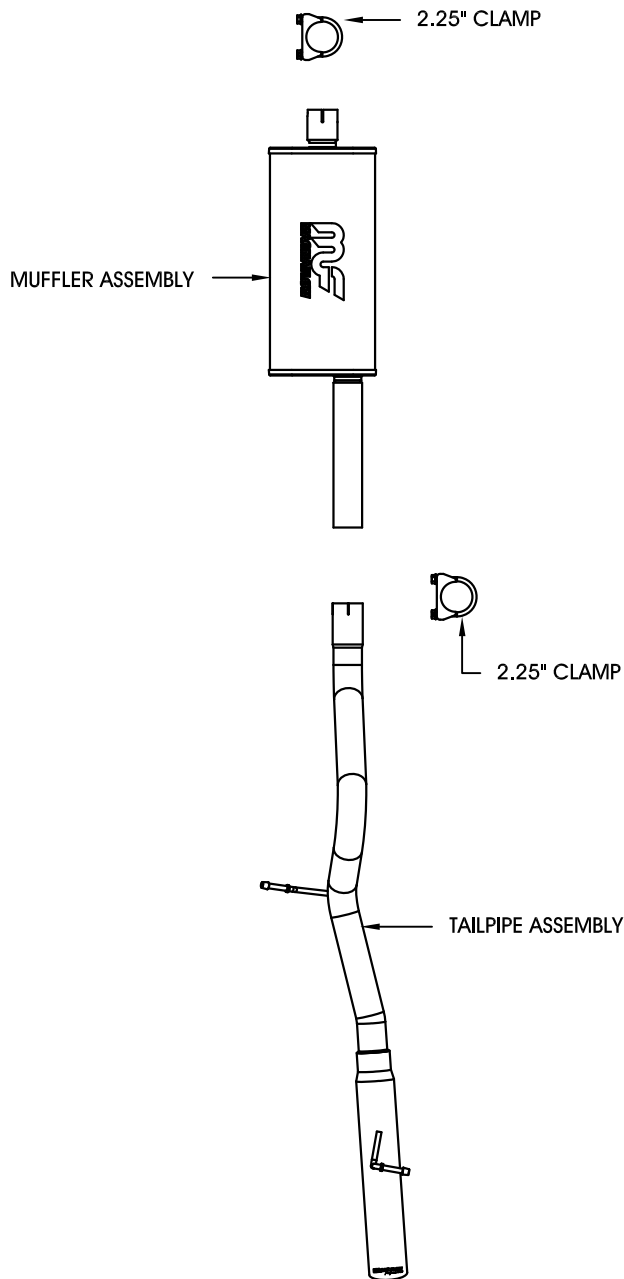

Step 1: (Carefully read all instructions before installation) Disconnect the vehicle's battery before removal of the OEM exhaust. This will allow the computer to reset itself with the new system, and prevent electrical accidents. Begin by cutting the tailpipe just ahead of the control arm. Remove the tailpipe from the OEM rubber insulators. Do not damage the OEM rubber insulators, as they will be re-used to mount the new system. Next, unbolt the clamp attaching the muffler to the catalytic converter, and remove it from the vehicle.

Step 2: Install the new muffler using the supplied 2.25" U-bolt clamp. Be sure to align the notch on the front extension pipe for proper fitment. Leave all fasteners loose for final adjustment of the complete system. Install the new tailpipe by fitting the welded hangers into the OEM rubber insulators and by fastening it to the muffler assembly using the supplied 2.25" band clamp.

Step 3: With all components mounted loosely, adjust the system for overall aesthetics and clearance of frame & bodywork. (MAGNAFLOW recommends at least 1/2" of clearance between the exhaust system and any body panels to prevent heat-related body damage or fire.)

Step 4: Once a final position has been chosen for the new system, evenly tighten all fasteners from front to rear. The supplied band clamps must be VERY tight to properly align the pipes and prevent leaks (Approximately 40ft-lbs). U-bolt clamps should be tightened to approximately 30-35ft-lbs. Inspect all fasteners after 25-50 miles of operation and retighten if necessary.

*MAGNAFLOW Performance Exhaust recommends professional installation on all their products

Technical support: 1-800-959-9226 ext. 4500