

1999-2003 FORD F-Series - 7.3L OFF ROAD

Note: MAGNAFLOW advises against the removal of catalytic converters. If the vehicle was originally equipped with a catalytic converter, this exhaust system is intended for off-road and racing applications only.

Warning: When working on under or around any vehicle exercise caution. Please allow vehicles exhaust system to cool before removal, as exhaust system temperatures may cause severe burns. If working without a lift, always consult vehicle manual for correct lifting specifications. Always wear safety glasses and ensure a safe work area. Serious injury or death could occur if safety measures are not followed.

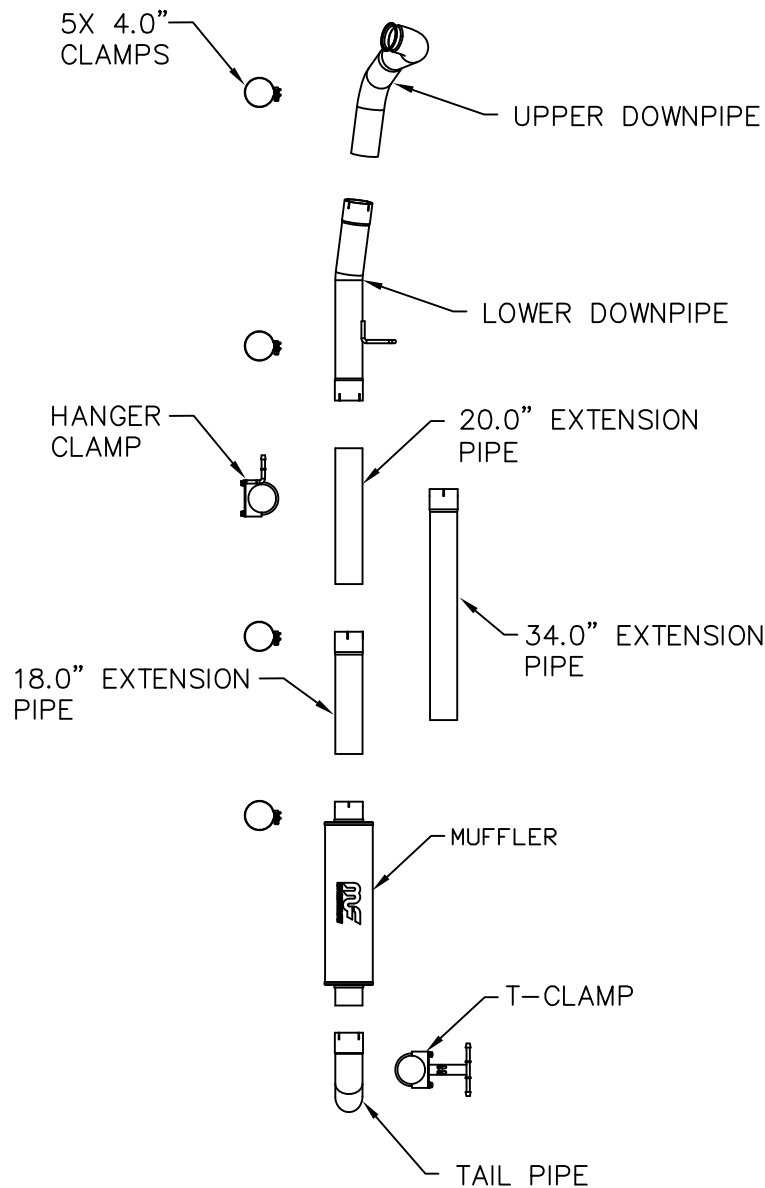

Step 1: (Carefully read all instructions before installation) Remove the clamp from the turbo-downpipe connection, but do not discard, as it will be re-used. Remove the system from the vehicle, taking care not to damage the rubber insulators. You may need to cut the extension pipe in front of the muffler to aid in removal of the OEM system.

Step 2: Layout all parts of your new system according to the diagram shown. Depending on cab design and/or bed length, some pipe extensions may not be required. The 4.0" hanger clamp is to be positioned on the middle pipe extension as needed, depending on the OEM insulator location. The Crew Cab-Long Bed uses the 20" extension pipe and the 34" extension pipe. The Crew Cab-Short Bed uses the 20" extension pipe and the 18" Extension Pipe. The Extended Cab-Long Bed uses the 20" Extension Pipe and the 18" Extension Pipe. The Extended Cab-Short Bed uses the 20" Extension Pipe only.

Step 3: Starting at the turbo, install the Upper Downpipe, re-using the OEM clamp (*Note: Do not overtighten*). Leave all components loose until the complete system is installed and positioned correctly. Working rearward, install the system engaging the system hangers with the OEM rubber insulators. The adjustable T-clamp is slotted to allow vertical alignment of the muffler and tailpipe assembly. Adjust the system tip to desired position and tighten the T-clamp. (MAGNAFLOW recommends at least 1/2" of clearance from the exhaust tip and any body panels to avoid heat-related bodywork damage or fire.)

Step 4: Once a final position has been chosen for the new system, evenly tighten all fasteners from front to rear. The band clamps must be VERY tight to properly align the pipes and prevent leaks (Approximately 40ft-lbs). U-bolt clamps should be tightened to approximately 30-35ft-lbs. Inspect all fasteners after 25-50 miles of operation and retighten if necessary.

*MAGNAFLOW Performance Exhaust recommends professional installation on all their products