

**2007 - 2011 Dodge Ram 6.7L 5" Pro**

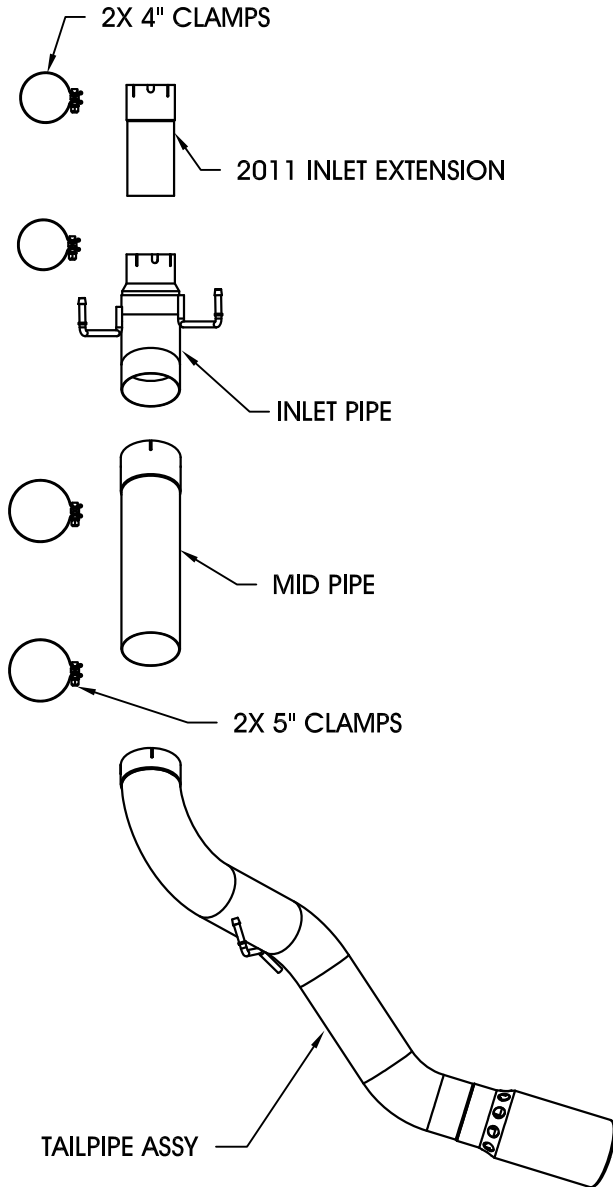

**Warning:** When working on, under, or around any vehicle exercise caution. Please allow the vehicle's exhaust system to cool before removal, as exhaust system temperatures may cause severe burns. If working without a lift, always consult vehicle manual for correct lifting specifications. Always wear safety glasses and ensure a safe work area. Serious injury or death could occur if safety measures are not followed.

**Step 1:** (Carefully read all instructions before installation) To remove the OEM system, you will need to cut the tailpipe just behind the OEM muffler. Working front to rear remove the OEM system. Disengage the welded tailpipe hangers from the rubber insulators and undo all attaching clamps. Do not damage or discard the OEM gasket, fasteners, or rubber insulators, as they will be reused to mount the new system.

**Step 2:** For year range '07 - '10 install the new inlet pipe directly to the OEM inlet extension. For year model '11 remove the OEM inlet extension pipe and replace it with the supplied inlet extension and loosely secure using the supplied clamp. Attach the inlet pipe to the inlet extension pipe (OEM pipe for '07 - '10). Install mid pipe and tail pipe assembly in the same fashion. Locate all welded hangers to the rubber isolators.

**Step 3:** With all components mounted loosely, adjust the system for overall aesthetics and clearance of frame & bodywork. (MAGNAFLOW recommends at least 1/2" of clearance between the exhaust system and any body panels to prevent heat-related body damage or fire.)

**Step 4:** Once a final position has been chosen for the new system, evenly tighten all fasteners from front to rear. The supplied band clamps must be VERY tight to properly align the pipes and prevent leaks (Approximately 40ft-lbs). U-bolt clamps should be tightened to approximately 30-35ft-lbs. Inspect all fasteners after 25-50 miles of operation and retighten if necessary.

\*MAGNAFLOW Performance Exhaust recommends professional installation on all their products

Technical support: 1-800-959-9226 ext. 4500

MAGNAFLOW Performance Exhaust - 22961 Arroyo Vista - Rancho Santa Margarita, CA 92688